

PTS 2,2 - 80  
PTS 3 - 80  
PTS 4 - 80  
PTS 15 - 80  
PTS 18,5 - 80

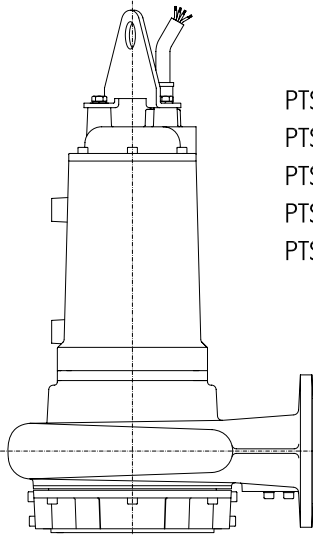

PTS 2,2 - 80N  
PTS 3 - 80N  
PTS 4 - 80N  
PTS 15 - 80N  
PTS 18,5 - 80N

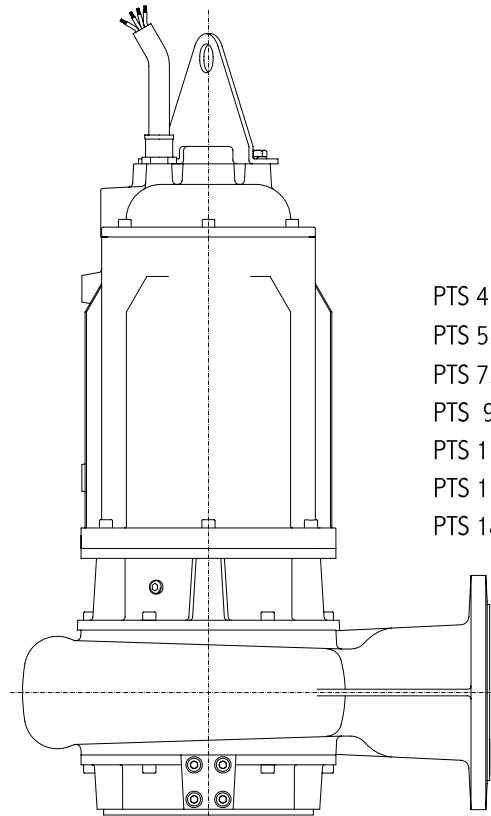

PTS 4 - 100  
PTS 5,5 - 100  
PTS 7,5 - 100  
PTS 9 - 100  
PTS 11 - 150  
PTS 15 - 150  
PTS 18,5 - 150

CARATTERISTICHE FUNZIONAMENTO - OPERATING DATA - CARACTERISTIQUES DE FONCTIONNEMENT

ELECTROPOMPA TIPO ELECTRIC PUMP TYPE ELECTROPOMPE TYPE	POTENZA MOTORE MOTOR RATING PUISSAN. MOTEUR	Giri/min RPM T/min	MANDATA DELIVERY REFOULEM.	PORTATA - CAPACITY - DEBIT [m <sup>3</sup> /h]														
				0	36	54	72	90	108	144	180	216	252	288	324			
				PORTATA - CAPACITY - DEBIT [l/sec]														
				0	10	15	20	25	30	40	50	60	70	80	90			
				PREVALENZA - HEAD - HAUTEUR [m]														
PTS 2,2 - 80 80N	2,2	1450	80	11,6	9,1	7,6	6	4,1										
PTS 3 - 80 80N	3			13,4	10,9	9,5	7,9	6,2	4,1									
PTS 4 - 80 80N	4			14,7	12,3	10,9	9,4	7,7	5,8									
PTS 15 - 80 80N	15			41,5	36,7	34,2	31,2	28,2	25,1									
PTS 18,5 - 80 80N	18,5			46,4	41,9	39,4	36,5	33,5	30,4	24,1								
PTS 4 - 100	4	1450	100	9,8	9,5	9	8,4	7,3	5,8									
PTS 5,5 - 100	5,5			12	11,6	11,2	10,6	9,7	8,3	3,7								
PTS 7,5 - 100	7,5			14,7	14,3	14	13,4	12,6	11,3	6,7								
PTS 9 - 100	9			16,1	15,7	15,4	14,9	14,1	12,7	8,7								
PTS 11 - 150	11			15,2	14,7	14,4	14	13,7	13,3	12,3	11,1	9,4	7,1	4,2				
PTS 15 - 150	15	150	150	18,6	18,1	17,8	17,4	17	16,7	15,6	14,2	12,8	10,8	8	4,8			
PTS 18,5 - 150	18,5			21,5	20,9	20,7	20,2	19,9	19,4	18,5	17,1	15,7	13,7	11	8			

DIAGRAMMI - PERFORMANCES RANGES - COURBES CARACTERISTIQUES

"PTS.. 80 / PTS.. 80N"

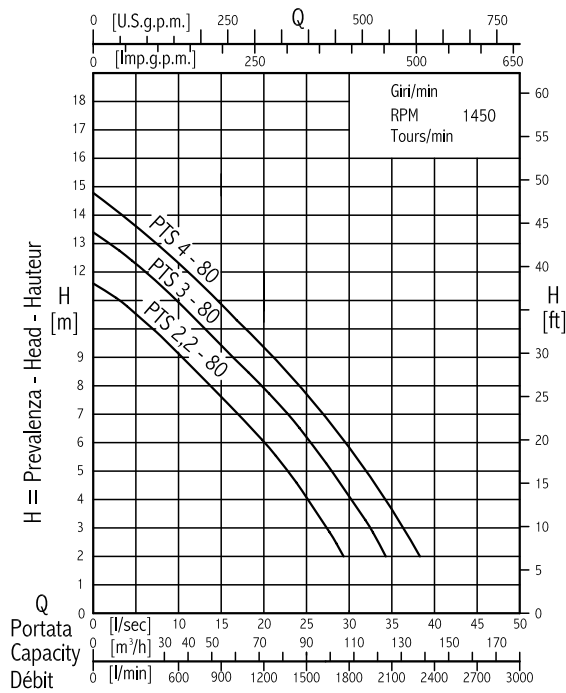

"PTS.. 80 / PTS.. 80N"

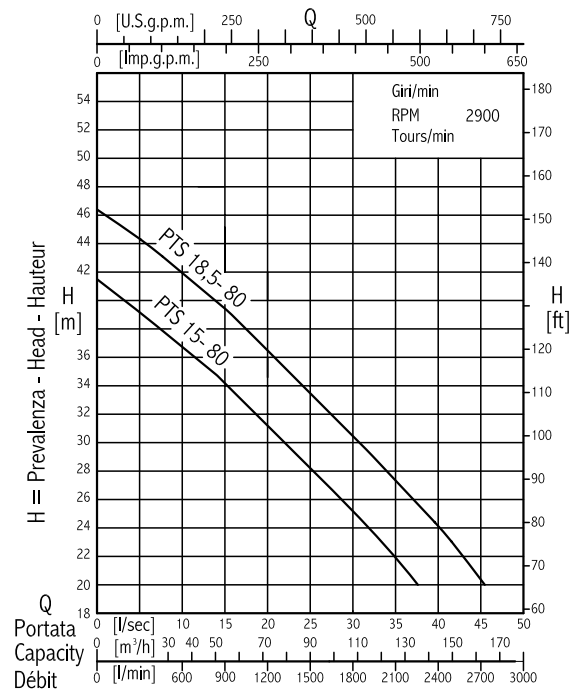

"PTS.. 100 "

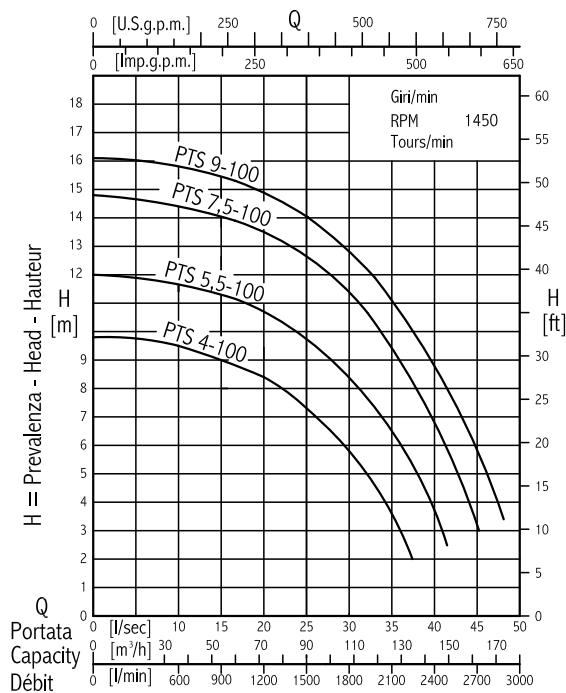

"PTS.. 150 "

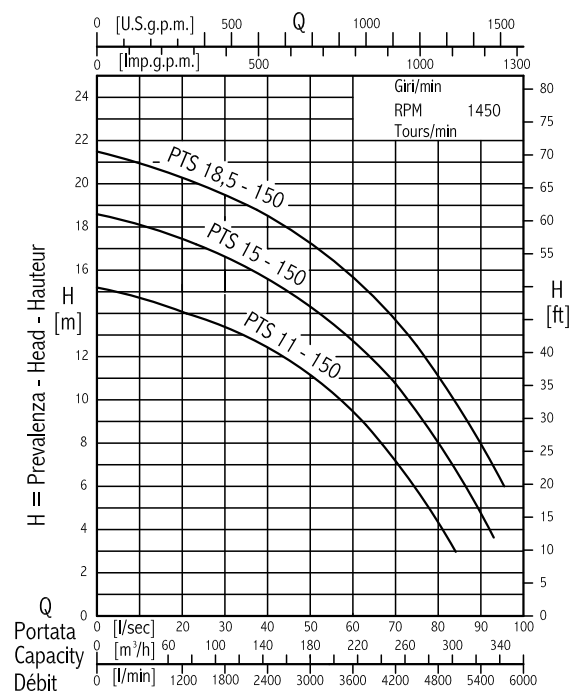

Curve per liquidi aventi densità 1 mm<sup>3</sup>/s - alla temperatura di 20° C.  
Curves established for liquid density 1 mm<sup>3</sup>/s - temperature 20° C.  
Courbes établies pour liquides densité 1 - viscosité 1 mm<sup>3</sup>/s - température 20° C.

CARATTERISTICHE STANDARD

Motori elettrici asincroni trifase con rotore a gabbia di scoiattolo.  
N°2 sonde termiche inserite nell'avvolgimento statorico.  
Grado di protezione "IP 68".  
Isolamento classe "F".  
Max profondità immersione 20 m.  
Max contenuto sostanze solide in sospensione 12%.  
Cavo sommergibile in neoprene H07-RN-F.  
pH liquido 5 ÷ 12.  
Max temperatura del liquido pompato 40°C.  
Servizio continuo.

STANDARD FEATURES

Asynchronous three phase electric motors with squirrel cage rotor.  
N.2 thermic probes installed in the stator winding.  
Protection "IP 68".  
"F" class insulation.  
Max submergence depth: 20 m.  
Max solid content in the liquid: 12%.  
Submersible H07-RN-F neoprene cable.  
Fluid pH 5 - 12.  
Max temperature of pumped liquid: 40°C.  
Continuous service.

CARACTERISTIQUES STANDARD

Moteurs électriques asynchrones triphasés, rotor à cage d'écurieul.  
N°2 sondes thermiques incorporées dans l'enroulement du stator.  
Degré de protection "IP 68".  
Isolement classe "F".  
Max profondeur d'immersion 20 m.  
Max contenu de substances solides en suspension 12%.  
Max pH du liquide 5 ÷ 12.  
Cable submersible en neoprene H07-RN-F.  
Max température du liquide pompe 40°C.  
Service continu.

ELETTROPOMPA TIPO ELECTRIC PUMP TYPE ELECTROPOMPE TYPE	CARATTERISTICHE MOTORI TRIFASE - 50 Hz - ALIMENTAZIONE 400 V ±10% 50 Hz - THREE-PHASE - MOTOR FEATURES - VOLTAGE RATING 400 V ±10% CARACTERISTIQUES DES MOTEURS TRIPHASES - 50 Hz - ALIMENTATION 400 V ±10%	POTENZA MOTORE MOTOR RATING PUISSANCE MOTEUR	AVVOLGIMENTI WINDINGS BOBINAGES	ASSORBIMENTO ABSORPTION INTENSITE	Giri/min RPM T/min	CAVO ALIMENTAZIONE FEEDING CABLE		CABLE D'ALIMENTATION	AVVIAMENTO	
		[kW]	[V]	[A (400V)]	n	N°cavi N°cables N°cables	N° conduttori cavo x sezione N° of wires x size N° conducteurs câble à section	Lunghezza cavo Cable length Longueur câble	Diretto Direct Direct	△
PTS 2,2 - 80 80N		2,2	230-400	5,3	1420	1	9 x 1,5	10	△	△
PTS 3 - 80 80N		3		6,8	1420					
PTS 4 - 80 / 80N 100		4		9,1	1405					
PTS 15 - 80 80N		15	400-690	31,2	2920		9 x 4		△	△
PTS 18,5 - 80 80N		18,5		36,5	2930					
PTS 5,5 - 100		5,5		12,5	1430		9 x 2,5		△	△
PTS 7,5 - 100		7,5		15,8	1440					
PTS 9 - 100		9		19	1440					
PTS 11 - 150		11		23,5	1450		9 x 4		△	△
PTS 15 - 150		15	30	1450						
PTS 18,5 - 150		18,5	36	1450						

Flangia UNI-PN10  
Flange UNI-PN10  
Bride UNI-PN10

Ø Fori  
Ø Holes  
Ø Trous

PTS 2,2 - 80  
PTS 3 - 80  
PTS 4 - 80  
PTS 15 - 80  
PTS 18,5 - 80

Flangia UNI-PN10  
Flange UNI-PN10  
Bride UNI-PN10

Ø Fori  
Ø Holes  
Ø Trous

PTS 2,2 - 80N  
PTS 3 - 80N  
PTS 4 - 80N  
PTS 15 - 80N  
PTS 18,5 - 80N  
PTS 4 - 100  
PTS 5,5 - 100  
PTS 7,5 - 100  
PTS 9 - 100  
PTS 11 - 150  
PTS 15 - 150  
PTS 18,5 - 150

	Flangia	Flange	Bride		
DN	L	M	P°	Ø Fori Ø Holes Ø Trous	N°Fori N°Holes N°Trous
80	160	200	90°	18	4
100	180	220	45°	18	8
150	240	285	45°	22	8

ELETTROPOMPA TIPO ELECTRIC PUMP TYPE ELECTROPOMPE TYPE	DIMENSIONI INGOMBRO [mm]			OVERALL DIMENSIONS [mm]			DIMENSIONS [mm]			PESO WEIGHT POIDS	
	DN	A	B	C	D	E	F	G	H		I
PTS 2,2 - 80	80	107	579	686	150	177	327	163	240	403	74
PTS 3 - 80											77
PTS 4 - 80											78
PTS 15 - 80			775	882							168,5
PTS 18,5 - 80											183
PTS 2,2 - 80N											75
PTS 3 - 80N			78								
PTS 4 - 80N			79								
PTS 15 - 80N			776	883							169,5
PTS 18,5 - 80N	184										
PTS 4 - 100	88										
PTS 5,5 - 100	100	108	659	767	155	190	345	173	263	436	122
PTS 7,5 - 100											128
PTS 9 - 100											133
PTS 11 - 150	150	150	805	955	197	257	454	226	342	568	213
PTS 15 - 150											226
PTS 18,5 - 150											229

INSTALLAZIONI POSSIBILI

POSSIBLE INSTALLATIONS

INSTALLATIONS POSSIBLES

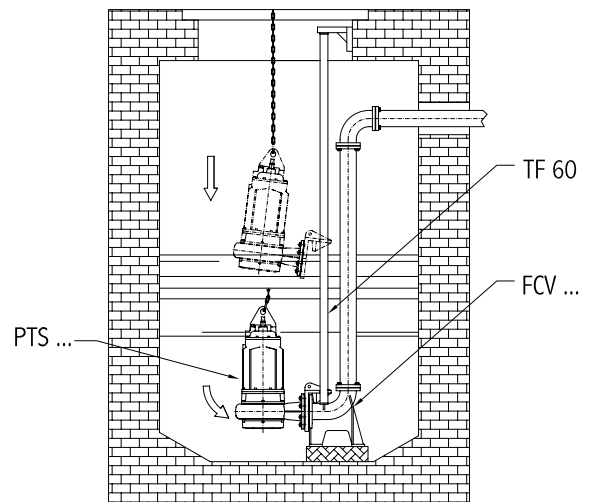
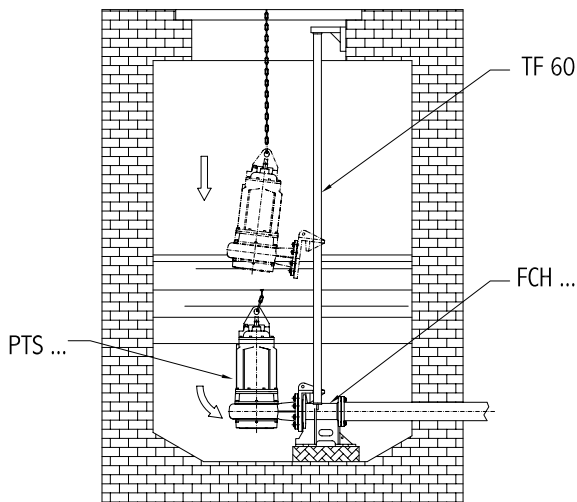
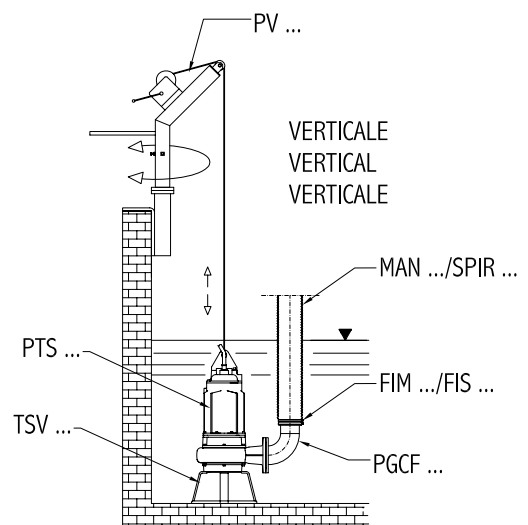
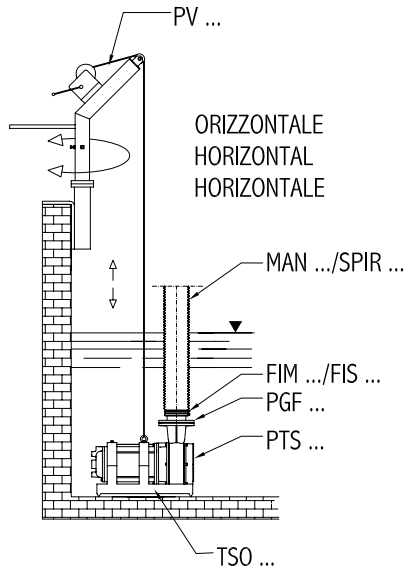
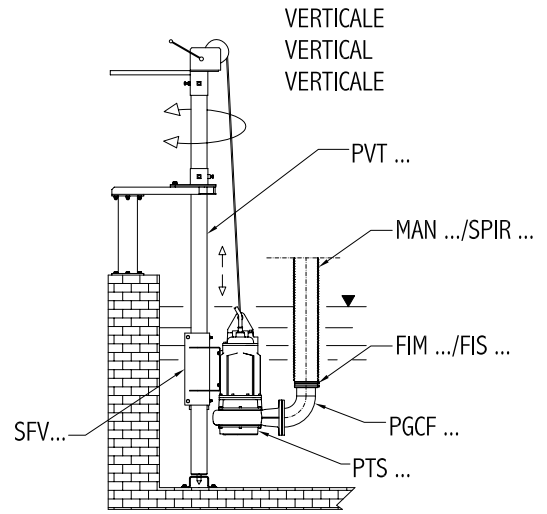
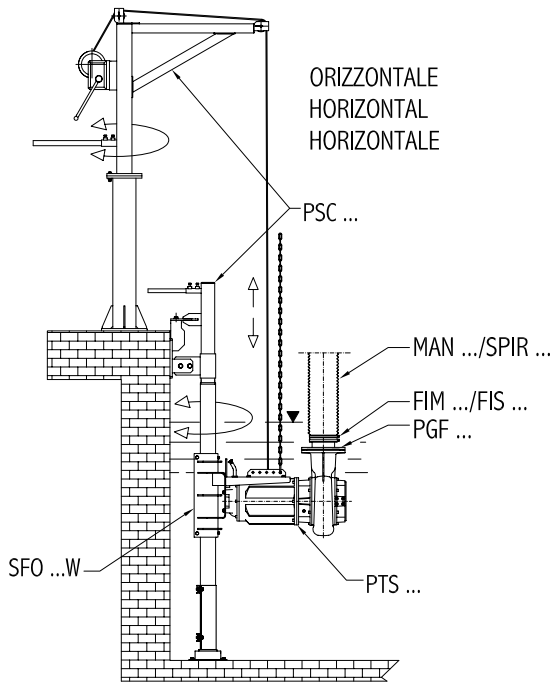

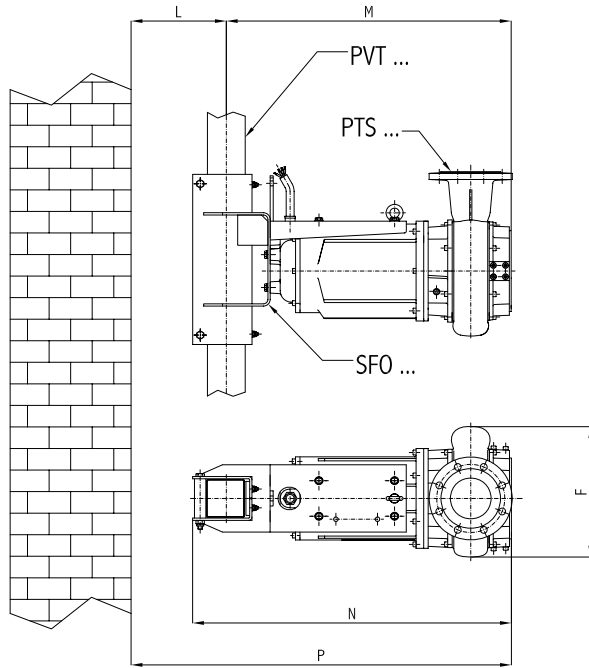

ELETTROPOMPA TIPO ELECTRIC PUMP TYPE ELECTROPOMPE TYPE	DIMENSIONI [mm] DIMENSIONS [mm]		PTS + PVT + SFO		
	F	L	M	N	P
PTS 2,2 - 80 80N	327	240	658	737	898
PTS 3 - 80 80N					
PTS 4 - 80 80N					
PTS 15 - 80 80N					
PTS 18,5 - 80 80N	345	250	843	933	1093
PTS 4 - 100					
PTS 5,5 - 100					
PTS 7,5 - 100	454	250	753	843	1003
PTS 9 - 100					
PTS 11 - 150					
PTS 15 - 150	910	1000	1160	1160	
PTS 18,5 - 150					

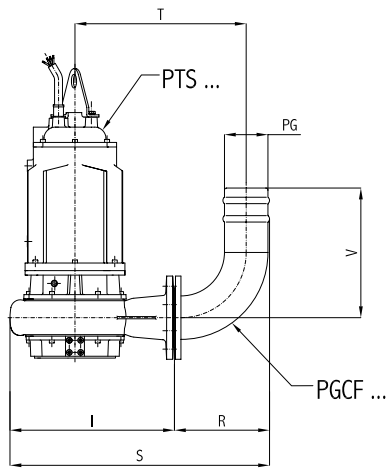

ELETTROPOMPA TIPO ELECTRIC PUMP TYPE ELECTROPOMPE TYPE	DIMENSIONI [mm] DIMENSIONS [mm]		PTS + PGCF			
	PG	I	R	S	T	V
PTS 2,2 - 80 80N	80	402	180	582	419	240
PTS 3 - 80 80N						
PTS 4 - 80 80N						
PTS 15 - 80 80N						
PTS 18,5 - 80 80N	100	436	220	656	483	290
PTS 4 - 100						
PTS 5,5 - 100						
PTS 7,5 - 100	150	568	320	888	660	380
PTS 9 - 100						
PTS 11 - 150						
PTS 15 - 150	568	320	888	660	380	
PTS 18,5 - 150						

		ACCESSORI	ACCESSORIES	ACCESSOIRES		
ELETTROPOMPA TIPO ELECTRIC PUMP TYPE ELECTROPOMPE TYPE	Paranco con verricello e tubo guida Hoist winch and rail pipe Treuil poulie et barre de guidage			Kit di sollevamento Lifting kit Kit de levage	Piantone Spacer Colonne	
	PTS 2,2 - 80 80N	PVT 80 / ...	.....	KIT PVT 80	.....	PT 80
	PTS 3 - 80 80N	PVT 100 / ...	.....	KIT PVT 100	.....	PT 100
	PTS 4 - 80 80N					
	PTS 4 - 100					
	PTS 5,5 - 100					
	PTS 7,5 - 100					
	PTS 9 - 100	.....	PVT 150 / ...	.....	KIT PVT 150	PT 100
	PTS 15 - 80 80N					
	PTS 18,5 - 80 80N					
PTS 11 - 150						
PTS 15 - 150						
PTS 18,5 - 150						
ELETTROPOMPA TIPO ELECTRIC PUMP TYPE ELECTROPOMPE TYPE	Fermacavo Cable stop Arrêt de câble	Staffa motore Motor bracket Console du moteur	Staffa motore Motor bracket Console du moteur	Grù con verricello Cranes and winch Grues et poulie	Staffa motore con rullini Motor bracket with rolls Console du moteur avec galets	
	PTS 2,2 - 80 80N	FC 16	SFO 80	SFV 80	PSC 80 / ...	SFO 80W
	PTS 3 - 80 80N	FC 20	SFO 100	SFV 100	PSC 100 / ...	SFO 100W
	PTS 4 - 80 80N					
	PTS 4 - 100					
	PTS 5,5 - 100					
	PTS 7,5 - 100					
	PTS 9 - 100	FC 26	SFO 150	SFV 150	PSC 100 / ...	SFO 150W
	PTS 15 - 80 80N					
PTS 18,5 - 80 80N						
PTS 11 - 150						
PTS 15 - 150						
PTS 18,5 - 150						
ELETTROPOMPA TIPO ELECTRIC PUMP TYPE ELECTROPOMPE TYPE	Staffa motore con rullini Motor bracket with rolls Console du moteur avec galets	Kit grù con verricello Cranes and winch kit Kit grues et poulie	Kit fissaggio tubo guida Fixing kit for rail pipe Kit de fixation pour tuyau de guide	Tubo guida Guide tube Tuyaux guide	Paranco con verricello Hoist and winch Treuil et poulie	
	PTS 2,2 - 80 80N	SFV 80W	KIT PVG 80	KIT PTG 80	KIT PGI 80	PV 80
	PTS 3 - 80 80N	SFV 100W	KIT PVG 100	KIT PTG 100	KIT PGI 100	PV 100
	PTS 4 - 80 80N					
	PTS 4 - 100					
	PTS 5,5 - 100					
	PTS 7,5 - 100					
	PTS 9 - 100	SFV 150W	KIT PVG 100	KIT PTG 100	KIT PGI 100	PV 150
	PTS 15 - 80 80N					
PTS 18,5 - 80 80N						
PTS 11 - 150						
PTS 15 - 150						
PTS 18,5 - 150						

	ACCESSORI	ACCESSORIES	ACCESSOIRES			
ELETTROPOMPA TIPO ELECTRIC PUMP TYPE ELECTROPOMPE TYPE	Telaio di sostegno Support frame Châssis de soutien	Telaio di sostegno Support frame Châssis de soutien	Catena Chain Chaîne	Staffa attacco catena e fune Bracket for chain and rope Support pour chaîne et corde	Portagomma flangiato Flanged hose connection Bridé	
PTS 2,2 - 80 80N PTS 3 - 80 80N PTS 4 - 80 80N	TSV 80	TSO 80	CAT INOX	SCF	PGF 80 PGF 80 Z	
PTS 4 - 100 PTS 5,5 - 100 PTS 7,5 - 100 PTS 9 - 100	TSV 100	TSO 100			PGF 100 PGF 100 Z PGF 120/100 PGF 120/100 Z	
PTS 15 - 80 80N PTS 18,5 - 80 80N	TSV 80	TSO 150			PGF 80 PGF 80 Z	
PTS 11 - 150 PTS 15 - 150 PTS 18,5 - 150	TSV 150				PGF 150 PGF 150 Z	
ELETTROPOMPA TIPO ELECTRIC PUMP TYPE ELECTROPOMPE TYPE	Curva flangiata portagomma Flanged hose connection Coude de refoulement pour tuyauterie flexible	Manichetta / Tubo flessibile Flexible rubber hose / PVC hose Tuyau flexible / Tuyau en PVC			Fascetta per manichetta / ... per tubo flessibile Clamp for rubber hose / Clamp for PVC hose Bande pour tuyau flexible / ... pour tuyau en PVC	Piede Duck-Foot pedestal Pied d'assise
PTS 2,2 - 80 80N PTS 3 - 80 80N PTS 4 - 80 80N	PGCF 80 PGCF 80 Z	SPIR 80			FIS 80	FCH 80-80
PTS 4 - 100 PTS 5,5 - 100 PTS 7,5 - 100 PTS 9 - 100	PGCF 100 PGCF 100 Z PGCF 120/100 PGCF 120/100 Z	MAN 100 SPIR 100 SPIR 120			FIM 100 / FIS 100 FIS 120	FCH 100-100
PTS 15 - 80 80N PTS 18,5 - 80 80N	PGCF 80 PGCF 80 Z	SPIR 80			FIS 80	FCH 80-80
PTS 11 - 150 PTS 15 - 150 PTS 18,5 - 150	PGCF 150 PGCF 150 Z	MAN 150 SPIR 150	FIM 150 FIS 150	FCH 150-150		
ELETTROPOMPA TIPO ELECTRIC PUMP TYPE ELECTROPOMPE TYPE	Piede Duck-Foot pedestal Pied d'assise	Tubo guida Guide tube Tuyaux guide				
PTS 2,2 - 80 80N PTS 3 - 80 80N PTS 4 - 80 80N	FCV 80-80	TF 60				
PTS 4 - 100 PTS 5,5 - 100 PTS 7,5 - 100 PTS 9 - 100	FCV 100-100					
PTS 15 - 80 80N PTS 18,5 - 80 80N	FCV 80-80					
PTS 11 - 150 PTS 15 - 150 PTS 18,5 - 150	FCV 150-200					

FCV 80-80  
 FCV 100-100  
 FCV 150-200

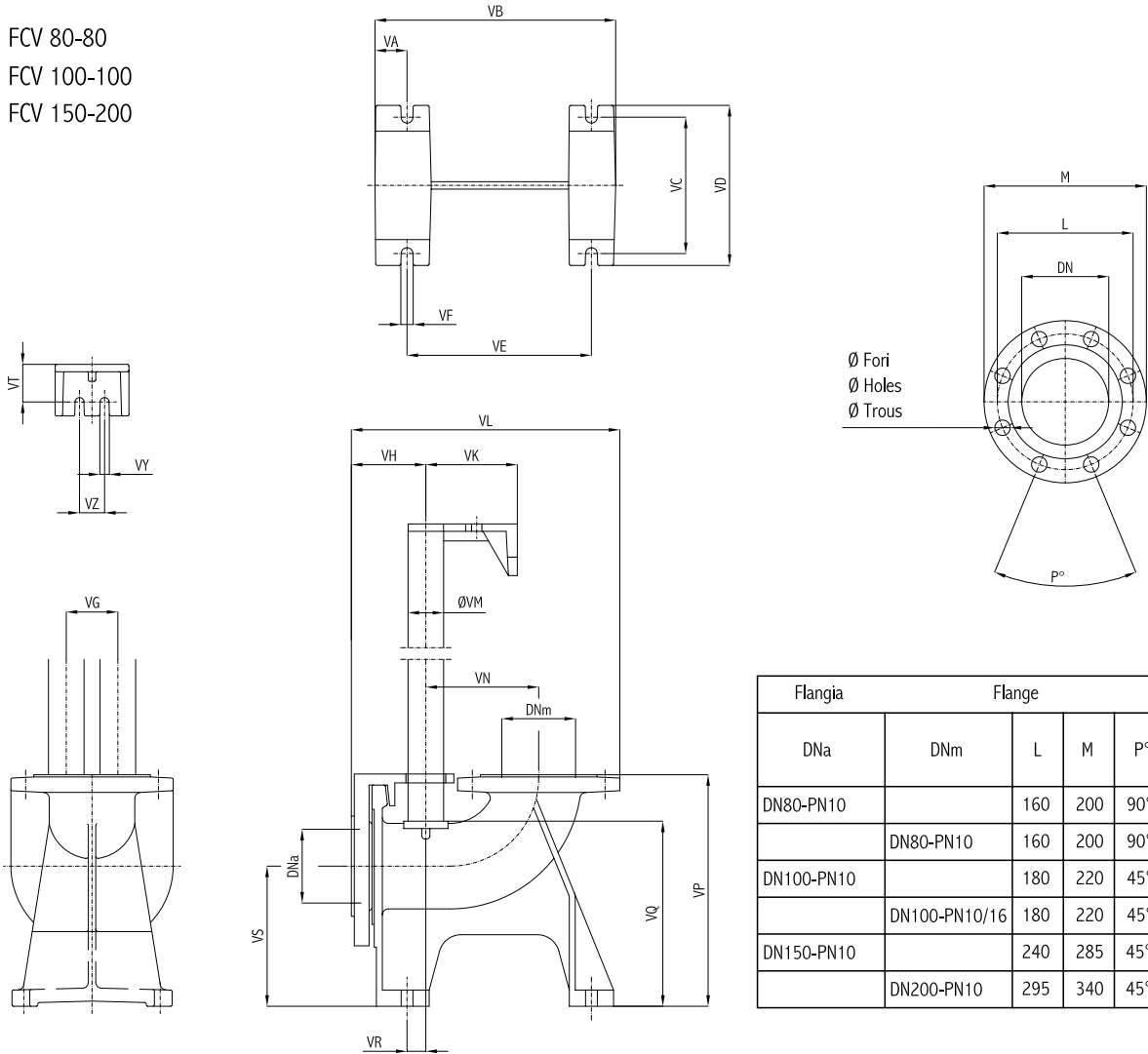

TIPO TYPE TYPE	DIMENSIONI INGOMBRO OVERALL DIMENSIONS DIMENSIONS [mm]																				
	DNa	DNm	VA	VB	VC	VD	VE	VF	VG	VH	VK	VL	VM	VN	VP	VQ	VR	VS	VT	VY	VZ
FCV 80-80N	DN80-PN10	DN80-PN10	30	316	200	222	250	16	100	141	124	417	2"	174	353	331	115	190	55	16	174
FCV 100-100N	DN100-PN10	DN100-PN10/16										447		194				219			
FCV 150-200	DN150-PN10	DN200-PN10	91	476	250	360	280	25		157,5	148	631		304	603	606	63	408	50	14	100

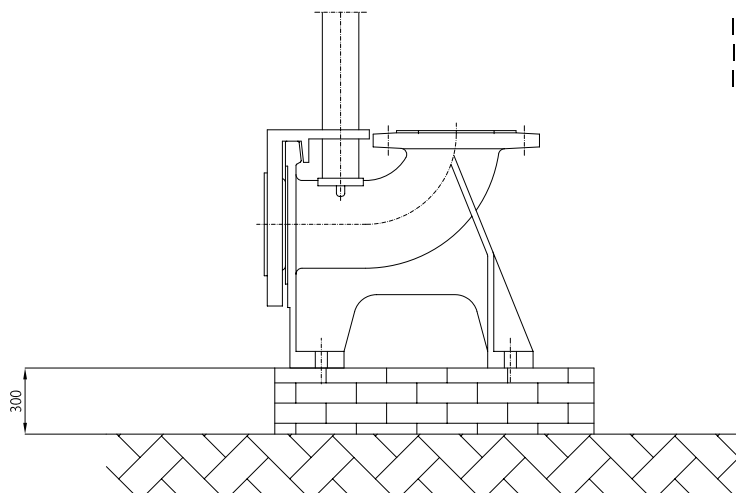

INSTALLAZIONE  
 INSTALLATION  
 INSTALLATION



FCH 80-80  
 FCH 100-100  
 FCH 150-150

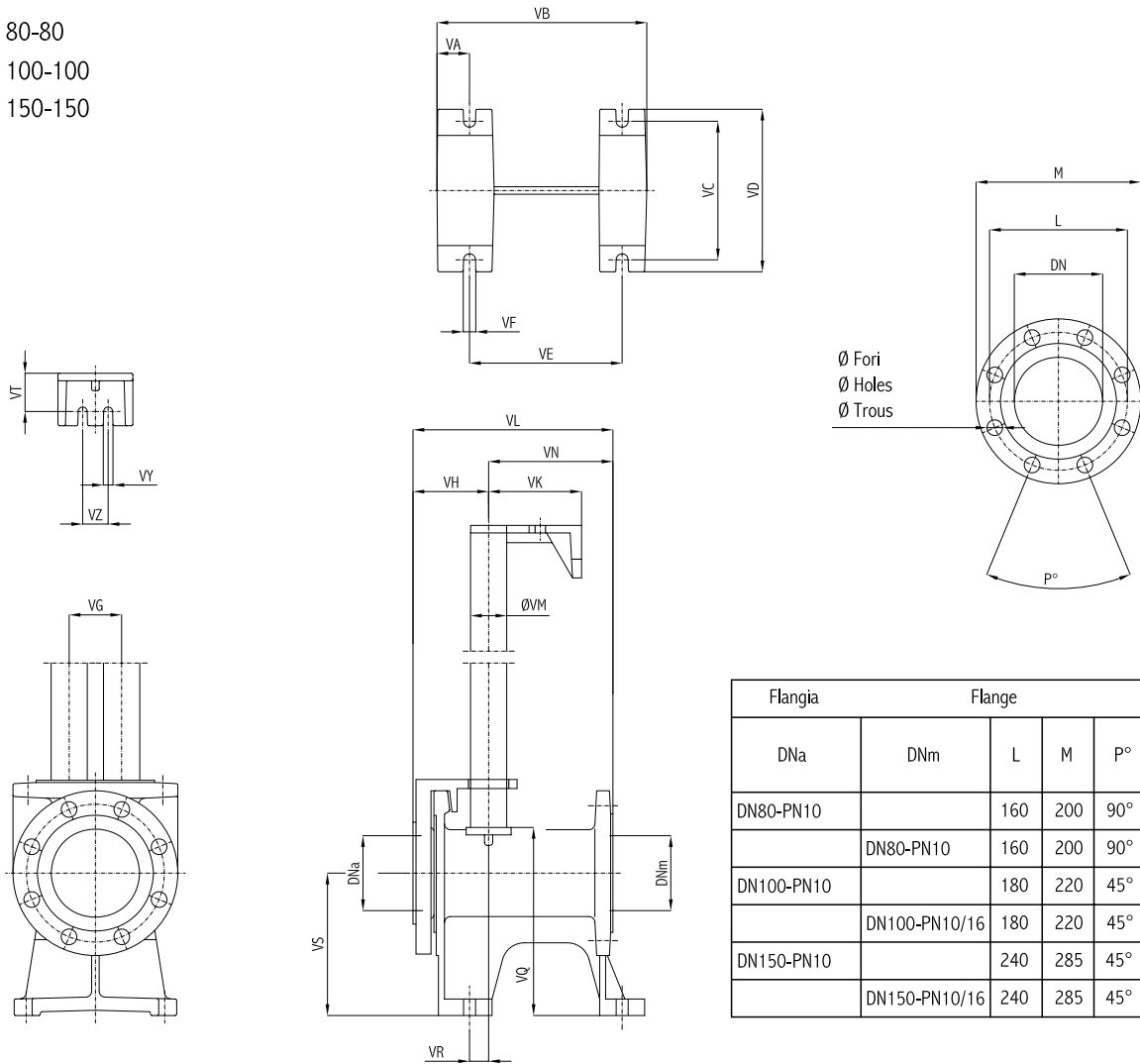

Flangia		Flange			Bride	
DNa	DNm	L	M	P°	Ø Fori Ø Holes Ø Trous	N°Fori N°Holes N°Trous
DN80-PN10		160	200	90°	M16	4
	DN80-PN10	160	200	90°	18	4
DN100-PN10		180	220	45°	M16	8
	DN100-PN10/16	180	220	45°	18	8
DN150-PN10		240	285	45°	M20	8
	DN150-PN10/16	240	285	45°	22	8

TIPO TYPE TYPE	DIMENSIONI INGOMBRO OVERALL DIMENSIONS DIMENSIONS [mm]																				
	DNa	DNm	VA	VB	VC	VD	VE	VF	VG	VH	VK	VL	VM	VN	VQ	VR	VS	VT	VY	VZ	
FCH 80-80	DN80-PN10	DN80-PN10	34	313	200	232		14		147		313		122	321	113		190			
FCH 100-100	DN100-PN10	DN100-PN10/16	40	320			250	16	100	148	320	2"	133	331	105		50	14	100		
FCH 150-150	DN150-PN10	DN150-PN10/16	91	406	250	360		25		152,5		406		169	330	58	240				

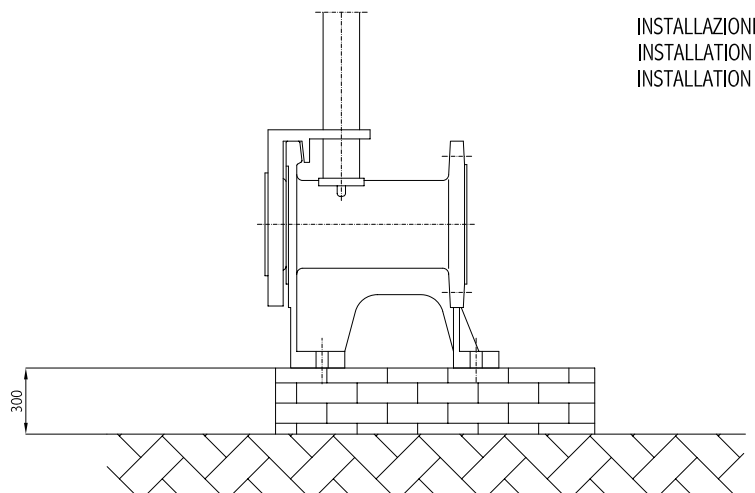

INSTALLAZIONE  
 INSTALLATION  
 INSTALLATION